

Innovative Technologies in Road Life

Kampati Spandana¹, Karupothula Sree Nikhila², D.Ramesh³ and Ganesh Pashikanti⁴

^{1,2} IIIrd Year B.Tech, Department of Electrical and Electronics Engineering, Malla Reddy Engineering College (A), India

^{3,4} Assistant Professor, Department of Electrical and Electronics Engineering, Malla Reddy Engineering College (A), India..

E-Mail: ganeshp5891@gmail.com

Abstract - This document gives the Automatic Room Lights using Arduino and PIR Sensor, where the lights in the room will automatically turn ON and OFF by detecting the presence of a human. Such Automatic Room Lights can be implemented in your garages, staircases, bathrooms, etc. where we do not need continuous light but only when we are present. Also, with the help of an automatic room light control system, you need not worry about electricity as the lights get automatically off when there is no person. So, in this DIY project, we have implemented Automatic Room Lights using Arduino and PIR Sensor.

Keywords - Arduino UNO, PIR Sensor, Relay Module, LED and 1N4007 PN Junction Diode.

I. INTRODUCTION

Automatic Room Lights System using Arduino is a very useful project as you need not worry about turning on and off the switches every time you want to turn on the lights. The main components of the Automatic Room Lights project are Arduino, PIR Sensor and the Relay Module. Out of the three components, the PIR Sensor is the one in focus as it is the main device that helps in detecting humans and human motion. In fact, the Automatic Room Lights project can be considered as one major application of the PIR Sensor. A similar concept is being already implemented in automatic toilet flush valves, hand dryers, etc.

II. MATERIALS AND METHODS

Components Required for Automatic Room Lights using Arduino

- 5V Relay Module (Relay Board)
- LED
- 100Ω Resistor (1/4 Watt)
- Connecting Wires
- Breadboard
- Power Supply

If you do not have a Relay Module, use the following components:

- 5V Relay
- 2N2222 (or BC547) NPN Transistor
- 1N4007 PN Junction Diode
- 1KΩ Resistor (1/4 Watt)

Component Description

PIR Sensor

We have already seen about PIR Sensor in the PIR Motion Sensor Tutorial and In order to control a single relay on the board, we need to use three pins of the relay module: VCC, GND and IN1.



Special Issue:

Department of Electrical and Electronics Engineering, Malla Reddy Engineering College (Autonomous).

© IJRAD. Volume 3, Issue 4, pp. 46-48, October 2019.

Relay Module

A Relay Module is a very useful component as it allows Arduino, Raspberry Pi or other Microcontrollers to control big electrical loads. We have used a 2-channel Relay Module in this project but used only one relay in it. The relay module used in this project is shown below.

Circuit Diagram of Automatic Room Lights using Arduino

The following image shows the circuit diagram of the project implemented using Arduino UNO, PIR Sensor and a Relay Module. If you do not have a relay module, you can make one yourself using very simple hardware. The following circuit diagram shows the project being implemented with the help of discrete components for the Relay Module.

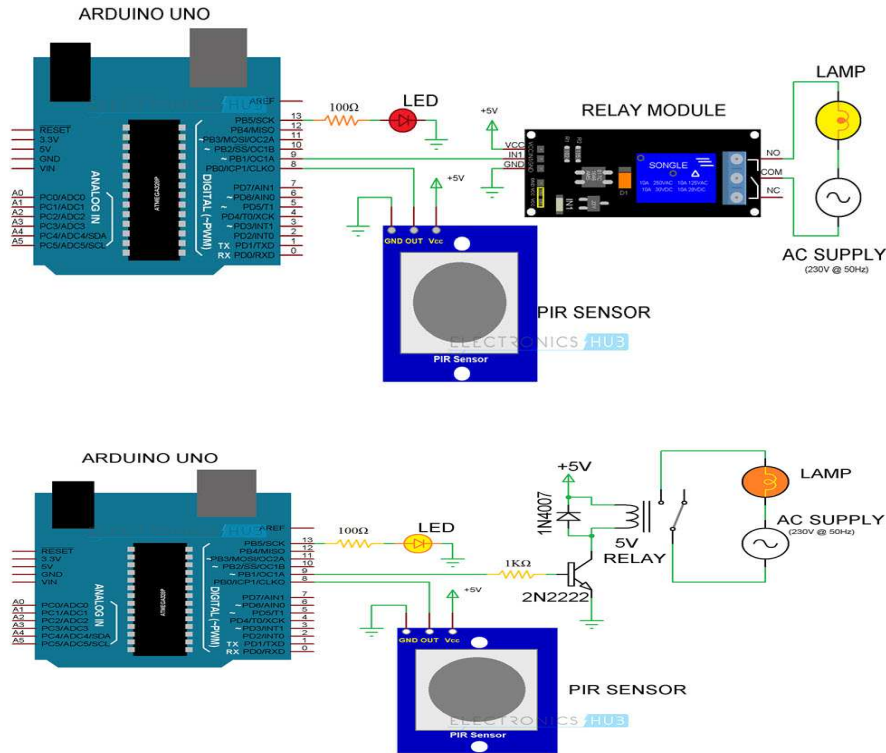

and Relay to mains supply. If you are unfamiliar with the connections, I strongly recommend having an adult supervision (or an expert supervision).

III. CIRCUIT DESIGN

PIR Sensor's Data OUT Pin is connected to Arduino's Digital I/O Pin 8. An LED is connected to pin 13 of Arduino to indicate whether the light is turned ON or OFF.

The IN1 pin of the Relay Module is connected to Pin 9 of Arduino. A bulb is connected to mains supply through relay. One terminal of the bulb is connected to one wire of the mains supply. The other terminal of the bulb is connected to the NO (Normally Open) contact of the Relay Module.

COM (Common) contact of the Relay is connected to the other wire of the mains supply. Be careful when connecting this part of the project.

IV. WORKING OF THE PROJECT

The Automatic Room Lights using Arduino and PIR Sensor is a simple project, where the lights in the room will automatically turn on upon detecting a human motion and stay turned on until the person has left or there is no motion. Working of this project is very simple and is explained here.

Initially, when there is no human movement, the PIR Sensor doesn't detect any person and its OUT pin stays LOW. As the person enters the room, the change in infrared radiation in the room is detected by the PIR Sensor.

V. RESULTS AND DISCUSSION

As a result, the output of the PIR Sensor becomes HIGH. Since the Data OUT of the PIR Sensor is connected to Digital Pin 8 of Arduino, whenever it becomes HIGH, Arduino will activate the relay by making the relay pin LOW (as the relay module is an active LOW module).

Special Issue:

Department of Electrical and Electronics Engineering, Malla Reddy Engineering College (Autonomous).

© IJRAD. Volume 3, Issue 4, pp. 46-48, October 2019.

This will turn the Light ON. The light stays turned ON as long as there is movement in front of the sensor. If the person takes a nap or leaves the room, the IR Radiation will become stable (there will be no change) and hence, the Data OUT of the PIR Sensor will become LOW. This in turn will make the Arduino to turn OFF the relay (make the relay pin HIGH) and the room light will be turned OFF.

Applications

I've already mentioned a few applications of the Automatic Room Lights concept. Some of them are:

- Garage Lights
- Bathroom Lights
- Hand Dryers
- Toilet Flushers
- Security Lights

VI. CONCLUSION

By using Automatic Room Lights using Arduino and PIR Sensor, where the lights in the room will automatically turn ON and OFF by detecting the presence of a human. Such Automatic Room Lights can be implemented in your staircases, bathrooms, etc.

REFERENCES

- [1] The working principle of an Arduino, Abuja, Electronics, Computer and Computation(ICECCO), 2014 11th International Conference, IEEE
- [2] A.V.Sudhakara Reddy, M. Ramasekhara Reddy, M. Vijaya Kumar "Stability Improvement During Damping of Low Frequency Oscillations with Fuzzy Logic Controller", International Journal of Engineering Research and Applications (IJERA), Vol.2, No.5, pp.1560-1565, September 2012.
- [3] G.Sathya, Fathima Shameema S, Jyothi MolSebastian, Jemysa K S "Automatic Rescue System for Ambulance and Authoritative Vehicles, Vol.2 - Issue 4 April.
- [4] B Bhargava Reddy, D Sivakrishna and A V Sudhakara Reddy "Modelling and Analysis of Wind Power Generation Using PID Controller", International Journal For Scientific Research & Development (IJSRD), Vol.1, No.9, pp.2045-2049, November 2013.
- [5] A. V. Sudhakara Reddy, Prof. M. Damodar Reddy, "Optimization of Distribution Network Reconfiguration Using Dragonfly Algorithm", Journal of Electrical Engineering, Vol.16, No.4, No.30, pp.273-282, ISSN:1582-1594, March 2017.
- [6] Ganiyu R. A., Arulogun O. T., Okediran O. O. "Development Of A Microcontroller-Based Traffic Light System For Road Intersection Control" International Journal Of Scientific & Technology Research Volume 3, Issue 5, May 2014 (2002).
- [7] A. V. Sudhakara Reddy, M. Damodar Reddy and Y. V. Krishna Reddy "Feeder Reconfiguration of Distribution Systems for Loss Reduction and Emissions Reduction using MVO Algorithm", Majlesi Journal of Electrical Engineering, Vol.12, No.2, pp.1-8, June 2018.
- [8] S.Bharathi, A.V.Sudhakara Reddy, Dr.M.Damodar Reddy, "Optimal Placement of UPFC and SVC using Moth-Flame Optimization Algorithm", International Journal of Soft Computing and Artificial Intelligence, ISSN: 2321-4046, Vol.5, No.1, pp.41-45, May 2017.
- [9] Kalyani S, A. V. Sudhakara Reddy and N. Vara Prasad "Optimal Placement of Capacitors in Distribution Systems for Emission Reduction Using Ant Lion Optimization Algorithm", International Journal of Current Advanced Research, Vol.7, No.11, pp.16339-16343, 2018.
- [10] Y V Krishna Reddy, M. Damodar Reddy and A. V. Sudhakara Reddy "Flower Pollination Algorithm for Solving Economic Dispatch with Prohibited Operating Zones and Ramp Rate Limit Constraints", Journal of Emerging Technologies and Innovative Research (JETIR), Vol.5, Iss.10, pp.498-505, 2018.
- [11] A. V. Sudhakara Reddy, N.Rajeswaran and D. Raja Reddy "Application of modified ALO to economic load dispatch for coal fired stations", International Journal of Recent Technology and Engineering (IJRTE), Vol.8, No.2, pp.2147-2152, 2019.
- [12] Y. Praveen Kumar Reddy, N. Vara Prasad and A. V. Sudhakara Reddy "A Power Sensor Tag with Interference Reduction for Electricity Monitoring of Two-Wire Household Appliances", Journal of Research in Science, Technology, Engineering and Management, Vol.6, No.1, pp.31-35, 2020.
- [13] A. V. Sudhakara Reddy, Balla Shiva Kumar and Ch. Narendra Kumar "A Hybrid Diesel Wind PV Based Energy Generation System", International Journal of Recent Technology and Engineering (IJRTE), Vol.8, No.4, pp.12157-12162, Nov 2019.
- [14] Sabarinath.G, T.Gowri Manohar and A. V. Sudhakara Reddy "Voltage Control and Power Loss Reduction in Distribution Networks using Distributed Generation", International Journal of Innovative Technology and Exploring Engineering (IJITEE), Vol.8, No.12, pp.2863-2867, 2019.
- [15] B. Bhargava Reddy, P. Nagarjuna and A. V. Sudhakara Reddy "Traffic Signal Control Using Lab View", Journal of Research in Science, Technology, Engineering and Management, Vol.6, No.1, pp.1-4, 2020.
- [16] A. V. Sudhakara Reddy and Dr. M. Damodar Reddy "Application of Whale Optimization Algorithm for Distribution feeder reconfiguration", i-manager's Journal on Electrical Engineering, Vol.11, No.3, pp.17-24, Jan-Mar 2018.
- [17] Y V Krishna Reddy, M. Damodar Reddy and A. V. Sudhakara Reddy "Flower Pollination Algorithm to Solve Dynamic Economic Loading of Units with Practical Constraints", International Journal of Recent Technology and Engineering (IJRTE), Vol.8, No.3, pp.535-542, 2019.
- [18] <http://arduino.cc/tutorial>